



Installation Guide

Table of Contents

Components In The Box - Single.....	3
Components In The Box - Double/Corner.....	4
Tools.....	5
Before You Install.....	6
Considerations.....	7
Single Unit Install.....	8
Double Unit Install.....	9
Fabric Characteristics.....	10
Warranty.....	11

Components In The Box

Single Unit

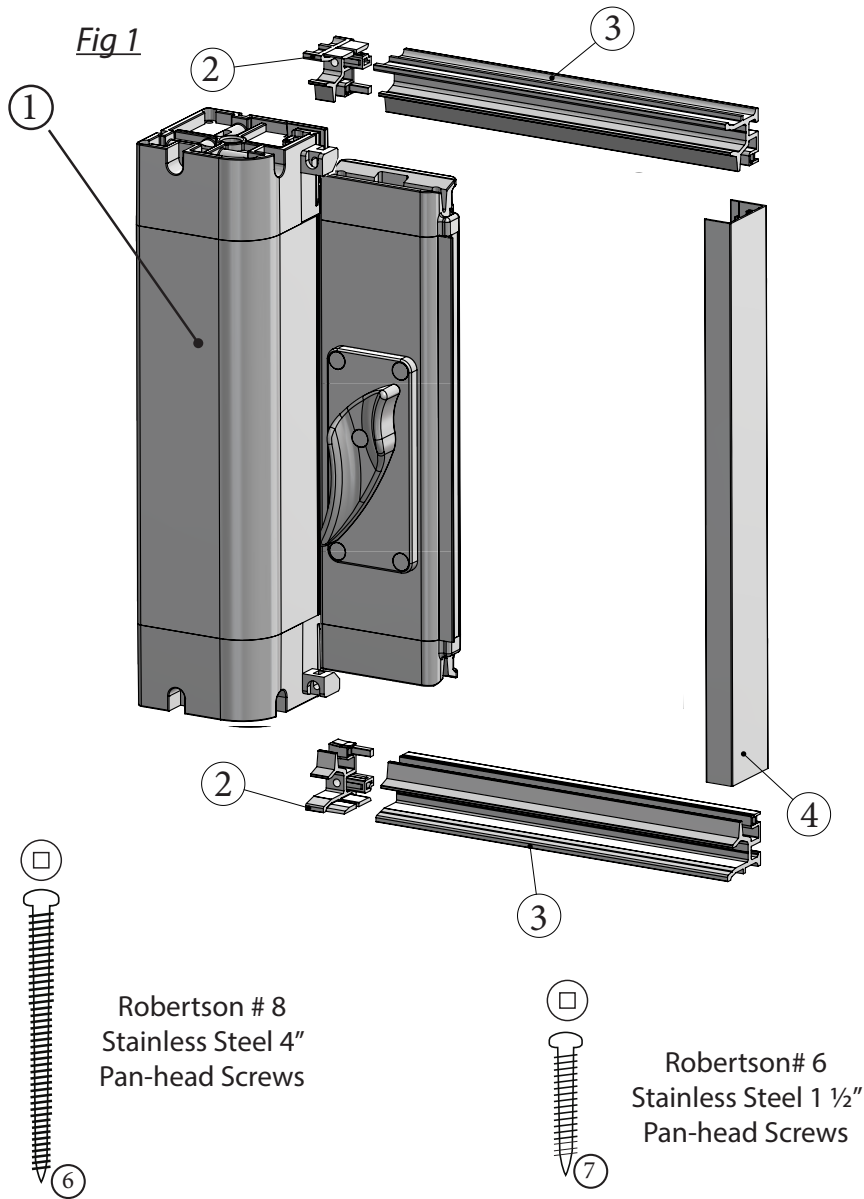

Optional Recessed Parts

70 - 2 7/8" wide by 1 1/4" tall
80 - 3 1/4" wide by 1 1/4" tall

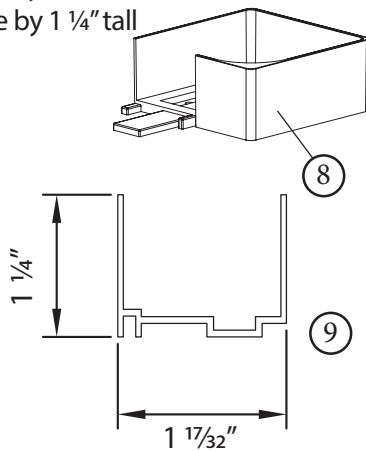

Part	Description	Quantity
1	VistaView Unit	1
2	Track Guide	2
3	Track	2
4	Receiver	1
5	Track Joiner	0
6	Housing Screw	2
7	Track/Receiver Screws	20
Recessed Kits Include		
8	Recessed Cup	1
9	Recessed Channel	1

Components In The Box

Double Unit

Fig 2

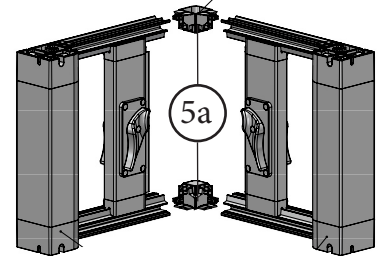
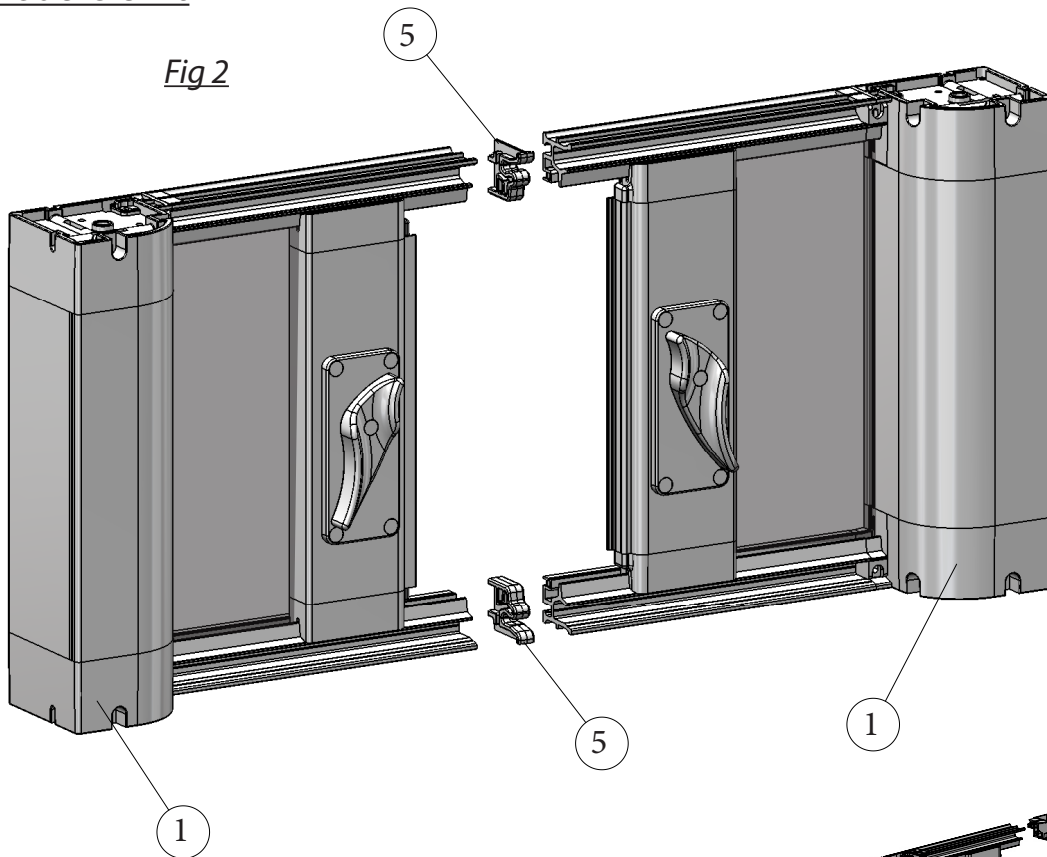

Corner Units

Optional Recessed Parts

70 - 2 7/8" wide by 1 1/4" tall
 80 - 3 1/4" wide by 1 1/4" tall

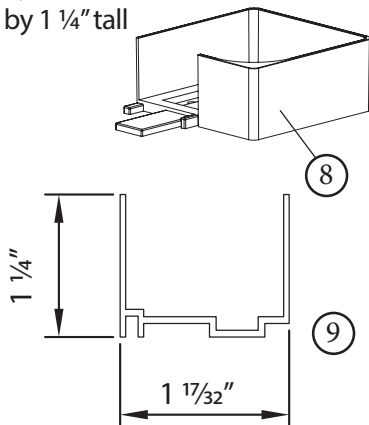

Part	Description	Quantity
1	VistaView Unit	2
2	Track Guide	4
3	Track	4
4	Receiver	0
5	Track Joiner	2
5(a)	Corner Joiner	2
6	Housing Screw	4
7	Track/Receiver Screws	25
Recessed Kits Include		
8	Recessed Cup	2
9	Recessed Channel	2

**Before You Begin Installation, You Will Need
the Following Tools**

Level



Tape Measure

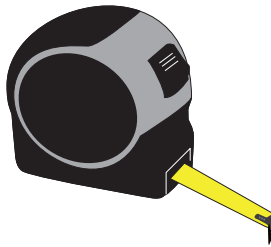

Pencil



Shims

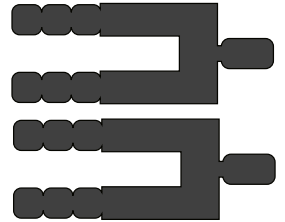

#8 Robertson
Screwdriver



9/64 and 1/8
Drill Bits



#1 Robertson
Driver Bit



Dry Silicone
Spray



Chop Saw

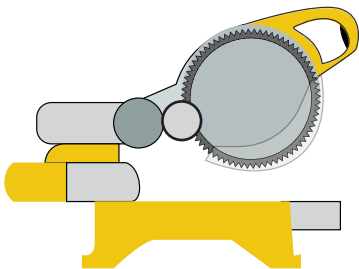

Drill



Step Ladder

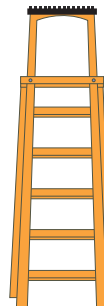

Vacuum



Before You Install

- Be sure to read and review complete installation instructions before you install
- Screens should be stored inside original packaging until the screens are ready to be installed
- Each screen system is custom made to each specific application
- Upon installation of screen the tracks are to be cut to length once housing is mounted
- Before installation inspect all products and components
- Damaged or missing components should be reported immediately
- Do not pull out screen system until tracks are in position
- Before screen is installed be sure that screen (zipper Teeth) are positioned correctly in housing zip guide as per Fig 1
- It is recommended that you install screens after door installation is complete and finished

FIGURE 1

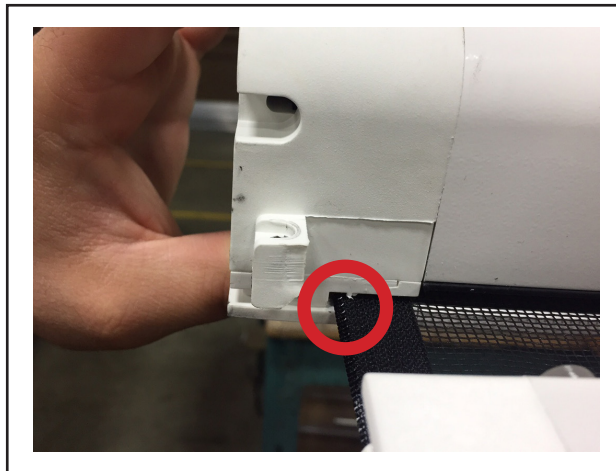

Do not operate screen system without using hand braking system!

Ensure screen is installed to be removable for future servicing!

Considerations

Concealed applications

The housing can be concealed but be sure that screen housing can be removed easily in the event that screen requires servicing. Concealing the upper track should be done with a removable piece of trim work, do not embed the upper track into header.

Exterior Applications

Screens that are installed on exterior with the track on top of the threshold then weep holes needs to be applied to the tracks.

ANY screen installed on the exterior of the home requires for all lower track pilot holes to be filled with silicone sealant before screws are fastened.

How to install weep holes:

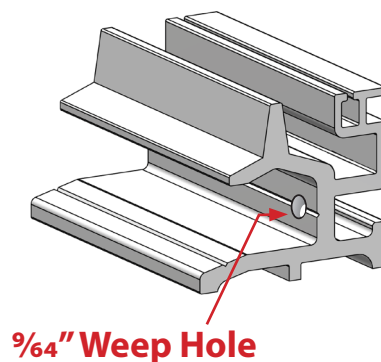

IMPORTANT NOTE: For exterior applications that are installed in unprotected areas please note that Recess Channel and tracks are not weather proof. Water Egress is the responsibility of the general contractor or builder.

To allow for additional water egress allow 1/4" gap where the track meets the receiver

Recessed Applications

Recessed cup and channel are assembled and screwed level in position before housing unit is dropped into position. Then track and housing are fitted together and inserted into recess. The cup secures the housing and no bottom housing screw is required.

The screen system does not trap water in housing, tracks or recess channel so any applications where door is exposed to weather the contractor or builder needs to provide considerations for water egress.

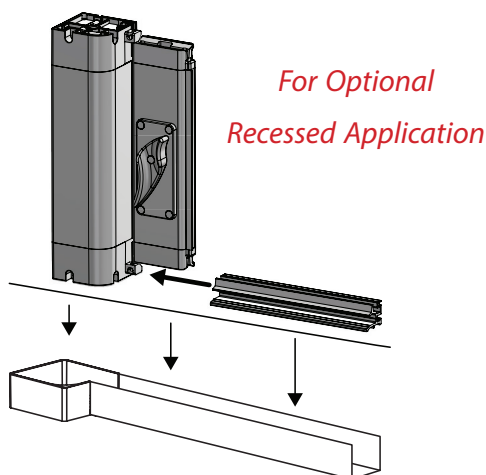

IMPORTANT NOTE: For exterior applications that are installed in unprotected areas please note that Recess Channel and tracks are not weather proof. Water Egress is the responsibility of the general contractor or builder

1 Mount Housing

Maneuver the housing into position so it is plumb left to right and front to back with the opening. You may wish to support it using a wedge. Fasten through the housing cap using provided housing screws, we recommend you pre-drill into the mounting surface.

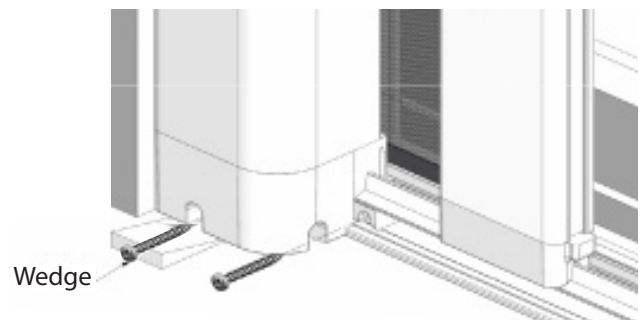

2 Mount Tracks

Note: You Must Install track guide on the end of track that goes against housing

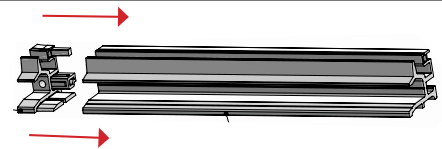

Before mounting the tracks installer should use a counter sinking bit to widen track zipper point. Then install track guide and smooth zipper groove with knife or flat head screw driver. This will help ensure that the groove and track guide will receive the zipper in good form.

Slide bottom track through the pull bar end-cap be sure zipper runs into the track guide. Butt the track against the housing so the holes in the track guide and housing end cap are aligned, fasten here using provided track screws.

Pre-drill 1/8" holes 16" apart and fasten track in place.

*Top Track Requires Two People

Pre-drill top track with 1/8" holes 16" apart. The top track is fed through the pull bar end cap in the same manner as the bottom. Butt the track against the housings so the holes in the track guide and housing end caps are aligned.

To ensure tracks are parallel bring pull-bar across in equal intervals and fasten track along the way.

Tracks must be 100% level and plumb with each other. Shimming may be required. You may wish to use a level.



Caution: Take Care not to damage the zipper whilst feeding into track through track guide

3 Mount Receiver

The receiver channel is installed on the side opposite of the housing. Position it so its bottom and the tracks bottoms will be in line.

The magnet inside the receiver is cut 2 1/4" short so the track can sit into the receiver channel further.

Pre-drill and fasten receiver channel in place using screws with 2` - 3` spacing in between.

Magnet in receiver must be opposite polarity of magnet on pull-bar

Position receiver & fix with provided screws.

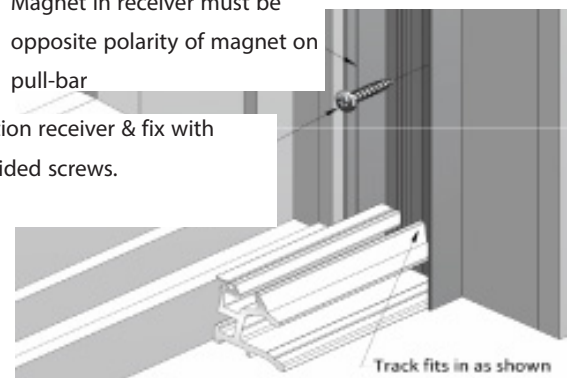

Double/Corner Unit Overview

1 Mount Housings

Maneuver the housing into position so it is plumb left to right and front to back with the opening. You may wish to support it using a wedge. Fasten through the housing cap using provided housing screws, we recommend you pre-drill into the mounting surface.

TIP: Add Total Length of track including track guide, track and joiner to find out how far apart housings need to be exactly.

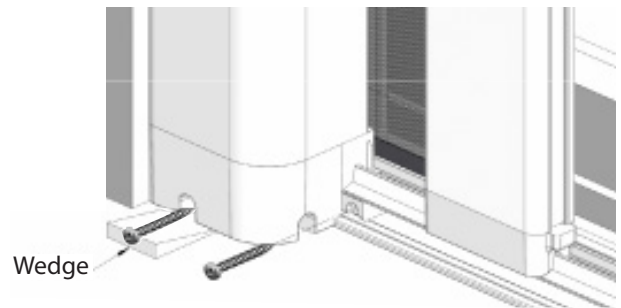

2 Mount Tracks

Note: You Must Install track guide on the end of track that goes against housing

Before mounting the tracks installer should use a counter sinking bit to widen track zipper point. Then install track guide and smooth zipper groove with knife or flat head screw driver. This will help ensure that the groove and track guide will receive the zipper in good form.

Slide bottom tracks through the pull bar end-caps, be sure zipper runs in groove. Butt the track against the housings so the holes in the track guide and housing end caps are aligned fasten here with track screws. Install one track joiner. Pre-drill tracks every 16".

Lift tracks together in the middle and bring down so tracks join together with track joiner. Do not fasten bottom track yet. (Corner Units use Joiner Corner at this Step)

***Top Track Requires Two People**
Repeat for the top track.

With one person supporting the tracks in the middle run the screens towards the middle. At this point fasten bottom and top tracks 2" from each track joiner. There should be some UP/DOWN movement in the pull bar.

Run screens back to their start positions. Slowly bring doors out. To ensure tracks are parallel bring pull-bar across in equal intervals and fasten track along the way.

Tracks must be 100% level with each other. Shimming may be required. You may wish to use a level.

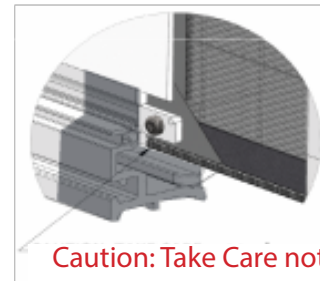
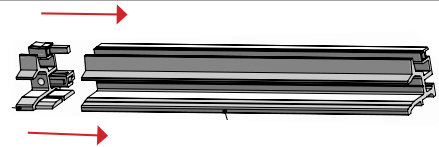

Caution: Take Care not to damage the zipper whilst feeding into track through track guide

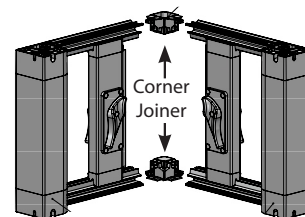
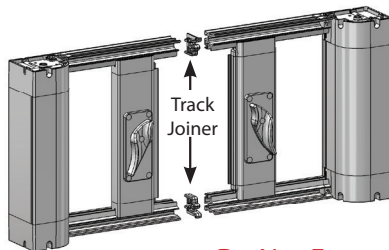

Do Not Extend Screens Past The Track Joiners

Spray Dry Silicone Spray into the opening that the mesh slides in.

Do not spray silicone where the brake is applied.

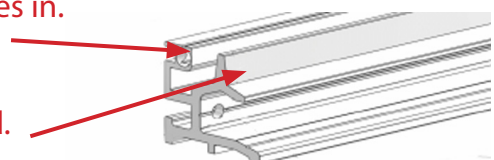

Fabric Characteristics

The woven Fiberglass 18x14 Mesh used in our retractable insect screens is manufactured with high-quality products, and woven with precision equipment, thereby making it the ideal material for large openings where extra strength is desirable. Even with the best mesh, components and manufacturing, there exists certain trait characteristics to mesh materials in all applications. In order to educate both the installer and the end user, some typical expected traits are detailed below. These traits are not exclusive to the material characteristics, incorrect measuring or installations may also cause or accentuate similar traits.

1) As a non-rigid material, it is normal to expect some “puckering” or “fingers” in the material, typical occurrences may be found at the weld point of the zipper, or spline, and the mesh. Correctly installed components can minimize or eliminate the opportunity for “puckering” or “fingers”.

2) The internal Spring Retention system is designed and balanced, to allow for the use of high quality, pleat-less screening systems, while ensuring simplicity in the installation, use and maintenance. In balancing the spring system to allow for ease of use in extending the screening system. With larger spans while “walking” the pull-bar back to the housing when not in use, within the range of expected performance “stacking” of the mesh may occur in proximity with the pull-bar to the housing and restrict the return of the pull-bar to the housing. In the event of stacking, “jogging” the pull-bar back and forth a few feet along the track will help to seat the mesh on the axle - always turn the handle when moving the pull-bar.

Optional Meshes & Finishes

The characteristics required in the manufacturing of extreme meshes (Super Mesh, Pet Mesh) while providing additional performance qualities, typically result in a thicker product, there by limiting the maximum horizontal spans achievable, and may predispose them to demonstrate the above mentioned characteristics. Precision engineered tracking systems may be finished in a range of colours and wood grain finishes. Keeping the tracks clean and correctly maintained with dry silicone will ensure high-performance and ease of use with all finishes. Wood grain tracks are finished with a base coat and a textured grain wrap and as such, screen systems employing the wood grain finish on the tracks will typically run louder.

WARRANTY

Wizard Industries Inc. Offers a limited **5 year warranty** on all components, excluding screen mesh, to the original purchaser of the VistaView from the date of installation.

This warranty is non-transferable and will remain intact for the original purchaser provided the product was installed by an Authorized Dealer and/or factory trained installer and has not been moved or altered in any way. Wizard warrants the components shall be free of defects in materials and workmanship. "Defects" are defined in this warranty as imperfections that impair the utility of the retractable screen. Wrinkles in the mesh or puckering along its edges in itself does not constitute a defect.

Defective components will be replaced free of charge for up to one year from the date of installation. After one year, Wizard will provide replacement components at no charge, but a service installation charge will apply.

The Limited Warranty does not include components that have been damaged by misuse, abuse, unauthorized repair or modification of the screen; normal weathering, fading, scratching, airborne or applied corrosive contaminants, acts of God or other causes beyond the control of Wizard Industries Inc.

If a component is defective, please contact your local authorized Wizard Retractable Screen dealer for service. Please retain your invoice as proof of purchase. Proof of purchase is required when submitting a warranty claim.



Maintenance

To obtain the best results and to maintain your screen in good working order the following tips and procedures should be observed.

1. Your new screen is NOT a heavy duty door. Correct operation and care is required to ensure years of trouble-free service.
2. To operate, rotate the plastic lever (this releases the brakes), slide screen to desired position and release.
3. Always operate screen from centre of handle.
4. Allow the spring to retract the screen - never push it back.
5. If possible use Wizard Dry Silicone into mesh slot in track to ensure the screens move freely. Do not spray where the brake is applied.
6. CLEANING: Track grooves must be cleaned regularly. Remove dust from grooves with brush.
7. To clean the mesh use a soft hand brush.
8. DO NOT allow rubbish to build up in tracks - vacuum/clean as necessary.
9. NOTE: Retractable screens are not storm proof. Strong, gusty winds may damage mesh.

WARNING

Spray Silicone into the opening that the mesh slides in.

Do not spray silicone where the brake is applied.

